

DES[®]
SINCE 1961



DISTILLING EQUIPMENT WITH SOUL





CONTENTS

ABOUT DES

About us	1
Column still components	3
Why copper?.....	5

COLUMN STILLS

Premium traditional pot still 200 L	7
Premium column still Aroma Max Compact 200 L	9
Premium column still 200 L Aroma Max column on top	11
Premium column still 200 L Aroma Max column	13
Premium column still 200 L Aroma Max and bubble plate column	15
Premium column still 200 L Aroma Max, bubble plate and column with copper filling	17
Premium column still 500 L Aroma Max column	19
Premium column still 500 L bubble plate column	21
Premium column still 500 L two columns with ten bubble plates	23
Premium column still 500 L Aroma Max and column with bubble plates	25
Premium column still 2x500 L Aroma Max column	27
Premium traditional pot still 1000 L	29
Premium column still 2x3000 L Aroma Max column	31
Premium Grappa column still 300 KG bubble plate column	33

CUSTOMER REFERENCES

Šurlan distillery - Serbia	37
Svarog distillery - Slovenia	38
Damijanić distillery - Croatia	39
Lynx Craft distillery - Croatia	40
Ginsanity distillery - Germany	41
Fermenthinks distillery - Italy	42
Rame distillery - Italy	43
Zona B distillery - Italy	44
Västerås distillery - Sweden	45
Lyden distillery - Sweden	46
Black Powder distillery - Great Britain	47
North Point distillery - Scotland	48
Atelier Constantberger distillery - Belgium	49
Anaiak distillery - France	50
Mezenk distillery - France	51
Le Vadrouilleur distillery - France	52
3 City distillery - Poland	53
Tessellis distillery - Poland	54
Aarau distillery - Switzerland	55
Basandere distillery - Spain	56

**DES**[®]
SINCE 1961

The company DES Subotica was founded in 1961 when the production of the best quality distilling equipment for brandy started, made of pure electrolytic copper of DHP quality. Developing production, improving technology - thanks to the experience and skill of the staff, we confirmed our existence and turned into a leader in the market of distilling equipment.

We have developed a range of products from small capacity hobby models to professional installations for large distilleries. We build success on a permanent and systematic investment in research and development, active launch of new products and applied technological solutions as well as constant improvement of existing products. Our brand is based on recognizable and long-lasting products with impeccable finishing for which we provide an excellent price, performance and quality ratio.

By escalating into new markets and expanding the distribution network, we make our products available to a large number of customers, on all continents. DES Subotica proudly accepts feedback information of satisfied customers who for over 65 years enjoy the production of the highest quality traditional drinks in DES still.

Carefully reflecting on the needs of our customers, we adapted and perfected the products. Today we enable customers to configure products according to their own requirements. We put the accent on creating premium products, capacity from 150 to 6000 L whose application results in the maximum flavor of the produced beverage.

We put special accent on the employment and education of persons with disabilities. This is confirmed by a sign of "FAIR PRODUCT" by Association of Companies for Professional Rehabilitation and Employment of Persons with Disabilities of the Republic of Serbia.



PREMIUM COLUMN STILLS

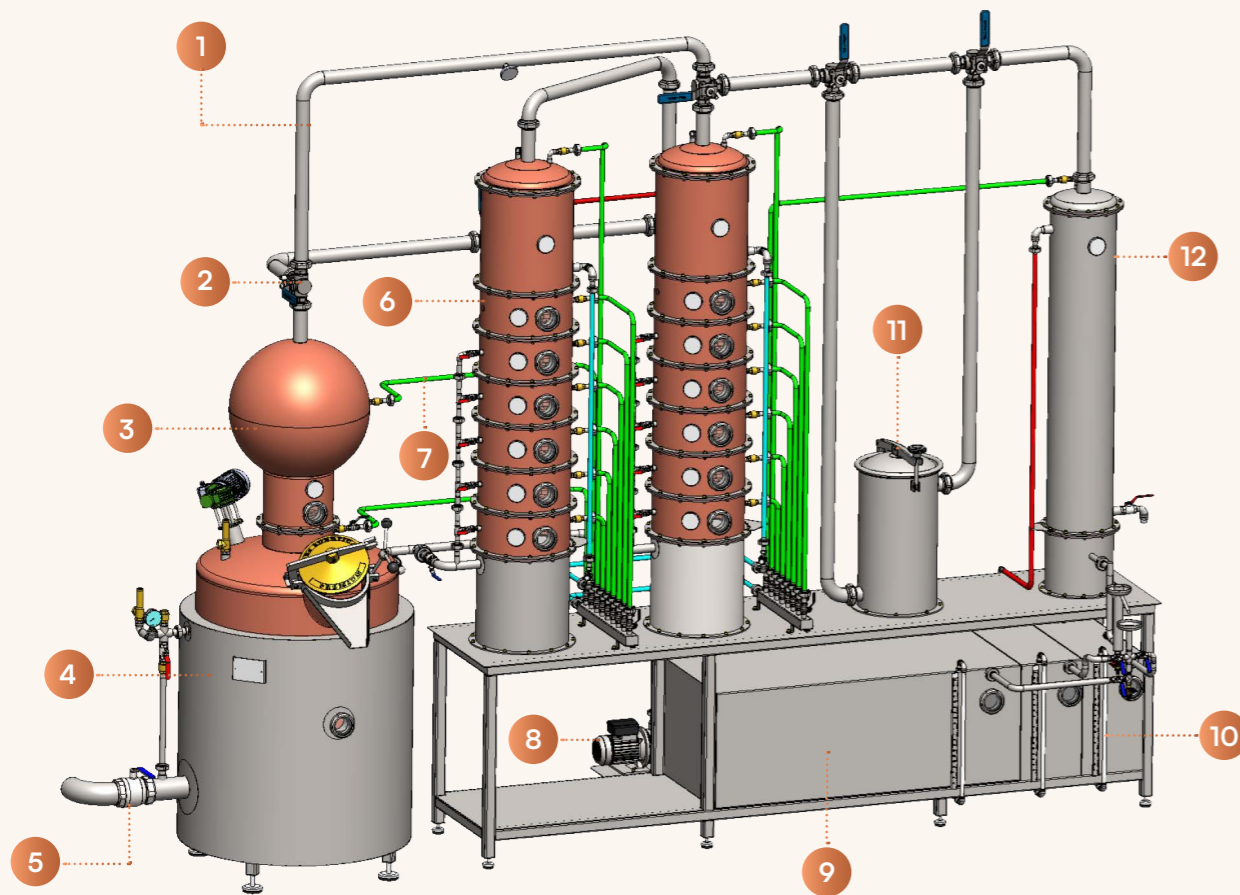

1	Connecting pipes	7	CIP pipe
2	3V valve	8	CIP pump
3	Alembic cap	9	Table/Receiver tank
4	Furnace	10	Receiver level gauge
5	Drain valve	11	Gin basket
6	Bubble plate segment	12	Cooler

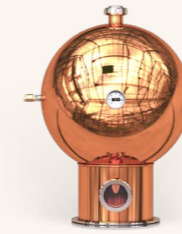

Alembic cap

Higher level of rectification, balanced extraction of steam from the pot into the rest of the system. The most traditional type of cap.



Whiskey cap

Lowest level of rectification, fastest extraction of steam from the pot into the rest of the system. Mandatory for whiskey.



Onion cap

Highest level of rectification, slowest extraction of steam from the pot into the rest of the system. Excellent for organoleptically complex distillates.

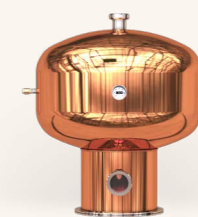

Alembic cap capacity 1500+ L

Higher level of rectification, balanced extraction of steam from the pot into the rest of the system. The most traditional type of cap. Designed for 1500+ L boilers.

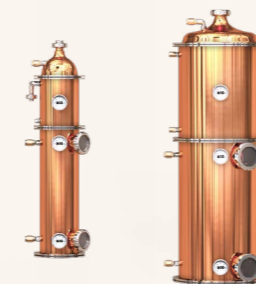

Aroma Max column

Aroma Max column for 200 L and 500+ L distilling pots. Interconnected Copper plates allow free contact of the descending reflux and the incoming steam. Adequate for the production of fruit brandies and other alcoholic beverages.

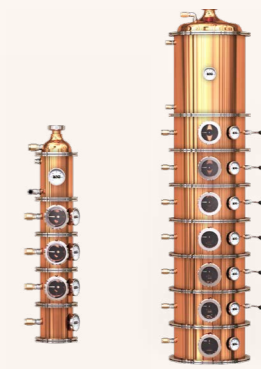

Bubble plate column

Bubble plate column for 200 L and 500+ L distilling pots. Designed for the production of high-proof alcohol in a single distillation cycle. A universal type of column designed for the production of various types of beverages.

WHY COPPER?

At the very beginning of the production of alcoholic beverages, many metals were used to make distillation stills (copper, iron, tin, aluminum, alloy-stainless steel, etc.), but copper proved to be by far the best metal which has been in use for thousands of years precisely because of its:

- ✦ physical design benefits
- ✦ corrosion resistance
- ✦ catalytic role in the quality of the distillate obtained
- ✦ excellent heat conductivity

Distillates obtained from an apparatus of glass, stainless steel or other materials have poor organoleptic characteristics (bitter, empty, metallic, dry, etc. smell and taste). Higher acid esters that bind to the copper produce a very pleasant aroma that adds to the quality of the final distillate. In addition to its resistance to organic acids, after silver - copper is the best thermal conductor and has a very positive effect on the taste and smell of distillate, it performs better than any other metal and therefore the distillate itself made in copper pot stills has a nicer smell, taste and quality.



PREMIUM TRADITIONAL POT STILL 200 L



Inlet opening



Drain opening



CIP cleaning system



Alembic, whisky or onion cap



Double wall



Electric, gas, solid fuel or steam heating

COMPONENTS	SPECIFICATIONS
Furnace material	Inox/Aisi 304 2 mm + (ceramic wool 25 mm + 1 mm brushed stainless steel)
Furnace working temperature	~110° C
Furnace working pressure	0.5 Bar
Heat source - electric heaters 2x9 kW	8-18 kW/h
Heat source - gas burner butane/natural 30-50 kW	4.72 kg/h-6.5 m³/h
Net capacity	200 L
Still material	Cu DHP/2 mm
Still cap - Alembic	Cu DHP/2 mm
Connecting pipes	Aisi 304 Ø40 mm × 1.5 mm
Cooling system	Aisi 304 Ø200 mm, shell 1 mm
Control unit	Manual setup
Vertical mixer - continuous 96 RPM	0.37 kW
CIP cleaning system	3 units
Aroma basket	10 L
Manufacturer's warranty	2 years

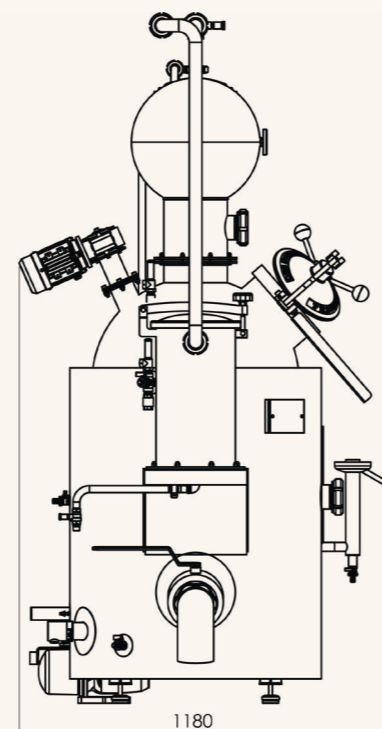
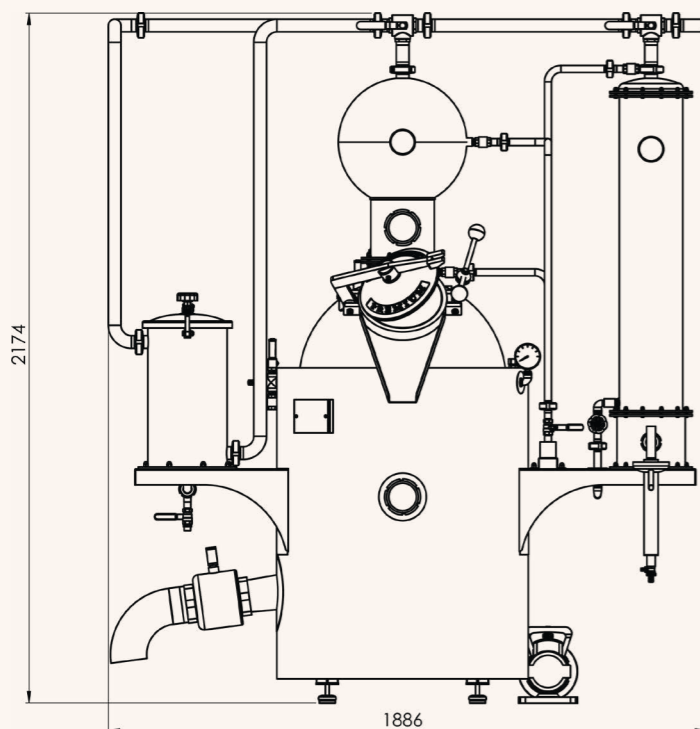

PREMIUM COLUMN STILL 200 L AROMA MAX COMPACT

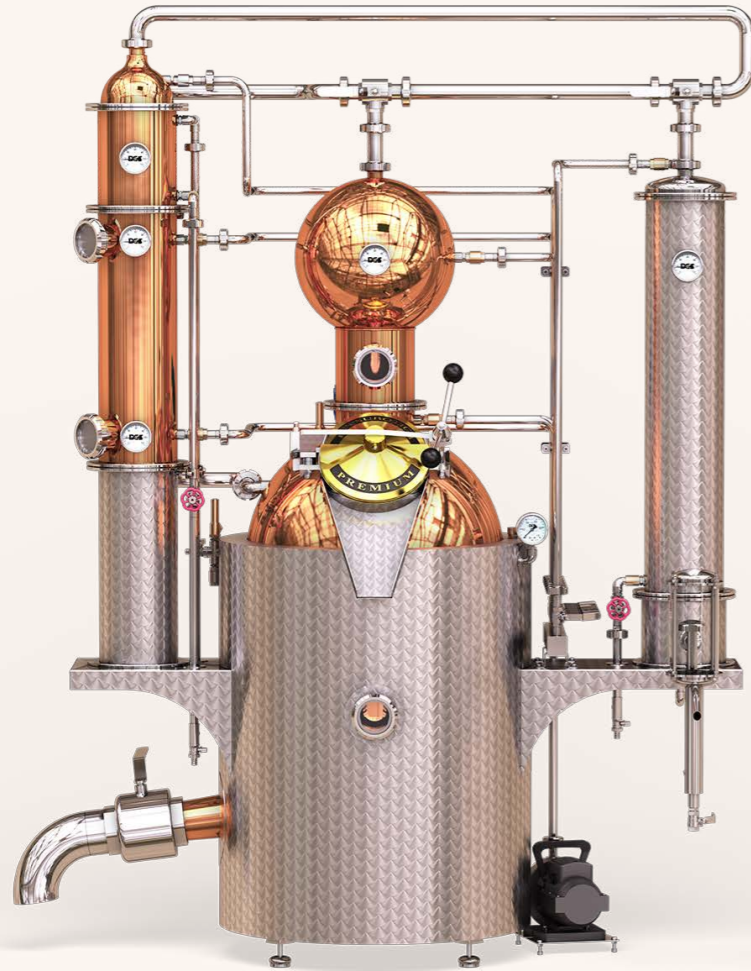

Inlet opening



Drain opening



CIP cleaning system



Alembic, whisky or onion cap



Aroma Max or bubble plate column



Electric, gas, solid fuel or steam heating

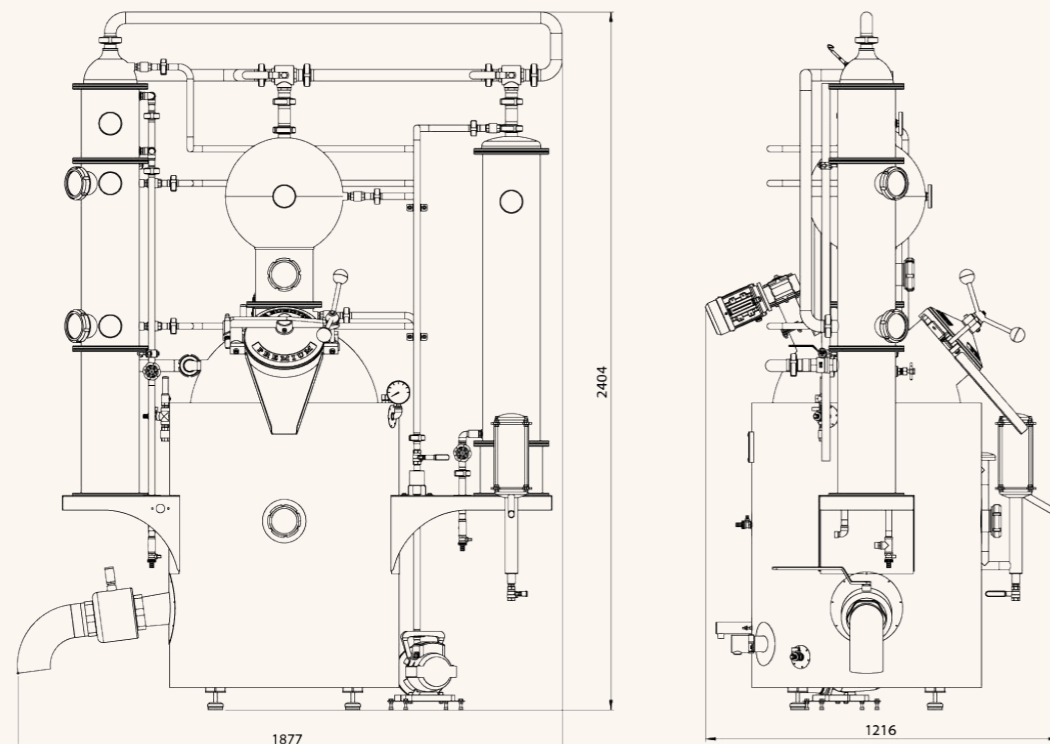

COMPONENTS	SPECIFICATIONS
Furnace material	Inox/Aisi 304 2 mm + (ceramic wool 25 mm + 1 mm brushed stainless steel)
Furnace working temperature	~110° C
Furnace working pressure	0.5 Bar
Heat source - electric heaters 2x9 kW	8-18 kW/h
Heat source - gas burner butane/natural 30-50 kW	4.72 kg/h-6.5 m ³ /h
Net capacity	200 L
Still material	Cu DHP/2 mm
Still cap - Alembic	Cu DHP/2 mm
Aroma Max column	Cu DHP/2 mm
Dephlegmator	Cu DHP/1.5 mm
Connecting pipes	Aisi 304 Ø40 mm × 1.5 mm
Cooling system	Aisi 304 Ø200 mm, shell 1 mm
Control unit	Manual setup
Vertical mixer - continuous 96 RPM	0.37 kW
CIP cleaning system	6 units
Aroma basket	10 L
Bypass system/by3V valve(s)	2 pieces
Manufacturer's warranty	2 years

PREMIUM COLUMN STILL 200 L AROMA MAX COLUMN ON POT



Inlet opening



Drain opening



CIP cleaning system



Alembic, whisky or onion cap



Aroma Max or bubble plate column



Electric, gas, solid fuel or steam heating

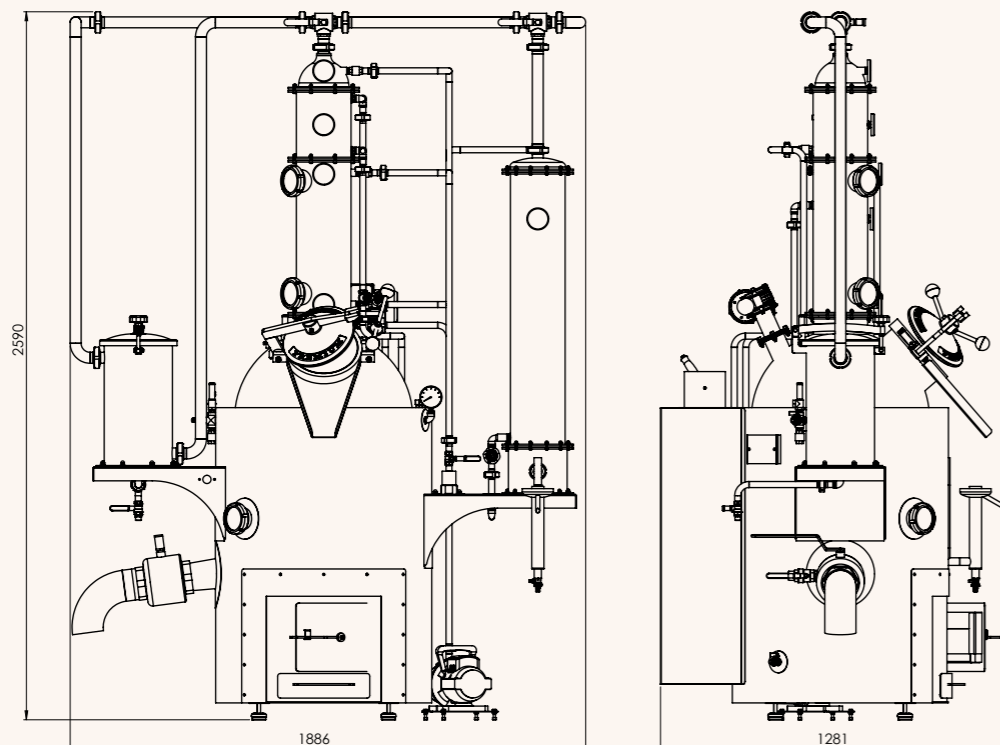

COMPONENTS

SPECIFICATIONS

Furnace material	Inox/Aisi 304 2 mm + (ceramic wool 25 mm + 1 mm brushed stainless steel)
Furnace working temperature	~110° C
Furnace working pressure	0.5 Bar
Heat source - electric heaters 2×9 kW	8-18 kW/h
Heat source - gas burner butane/natural 30-50 kW	4.72 kg/h-6.5 m³/h
Net capacity	200 L
Still material	Cu DHP/2 mm
Still cap - Alembic	Cu DHP/2 mm
Aroma Max column	Cu DHP/2 mm
Dephlegmator	Cu DHP/2 mm
Connecting pipes	Aisi 304 Ø40 mm × 1.5 mm
Cooling system	Aisi 304 Ø200 mm, shell 1 mm
Control unit	Manual setup
Vertical mixer - continuous 96 RPM	0.37 kW
CIP cleaning system	5 units
Aroma basket	10 L
Manufacturer's warranty	2 years

PREMIUM COLUMN STILL 200 L AROMA MAX COLUMN



Inlet opening



Drain opening



CIP cleaning system



Alembic, whisky or onion cap



Aroma Max or bubble plate column



Electric, gas, solid fuel or steam heating

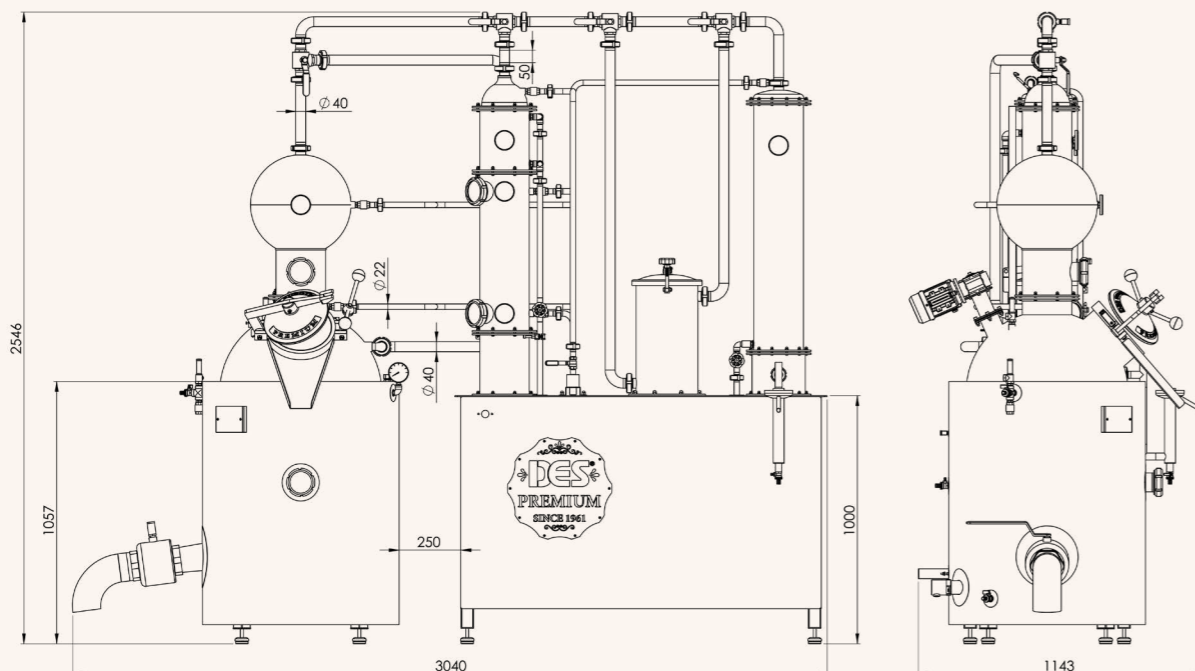

COMPONENTS	SPECIFICATIONS
Furnace material	Inox/Aisi 304 2 mm + (ceramic wool 25 mm + 1 mm brushed stainless steel)
Furnace working temperature	~110° C
Furnace working pressure	0.5 Bar
Heat source - electric heaters 2x9 kW	8-18 kW/h
Heat source - gas burner butane/natural 30-50 kW	4.72 kg/h-6.5 m ³ /h
Net capacity	200 L
Still material	Cu DHP/2 mm
Still cap - Alembic	Cu DHP/2 mm
Aroma Max column	Cu DHP/2 mm
Dephlegmator	Cu DHP/2 mm
Connecting pipes	Aisi 304 Ø40 mm × 1.5 mm
Cooling system	Aisi 304 Ø200 mm, shell 1 mm
Control unit	Manual setup
Vertical mixer - continuous 96 RPM	0.37 kW
CIP cleaning system	6 units
Bypass system/by3V valve(s)	4 pieces
Aroma basket	10 L
Manufacturer's warranty	2 years

PREMIUM COLUMN STILL 200 L AROMA MAX AND BUBBLE PLATE COLUMN



Inlet opening



Drain opening



CIP cleaning system



Alembic, whisky or onion cap



Aroma Max or bubble plate column



Electric, gas, solid fuel or steam heating

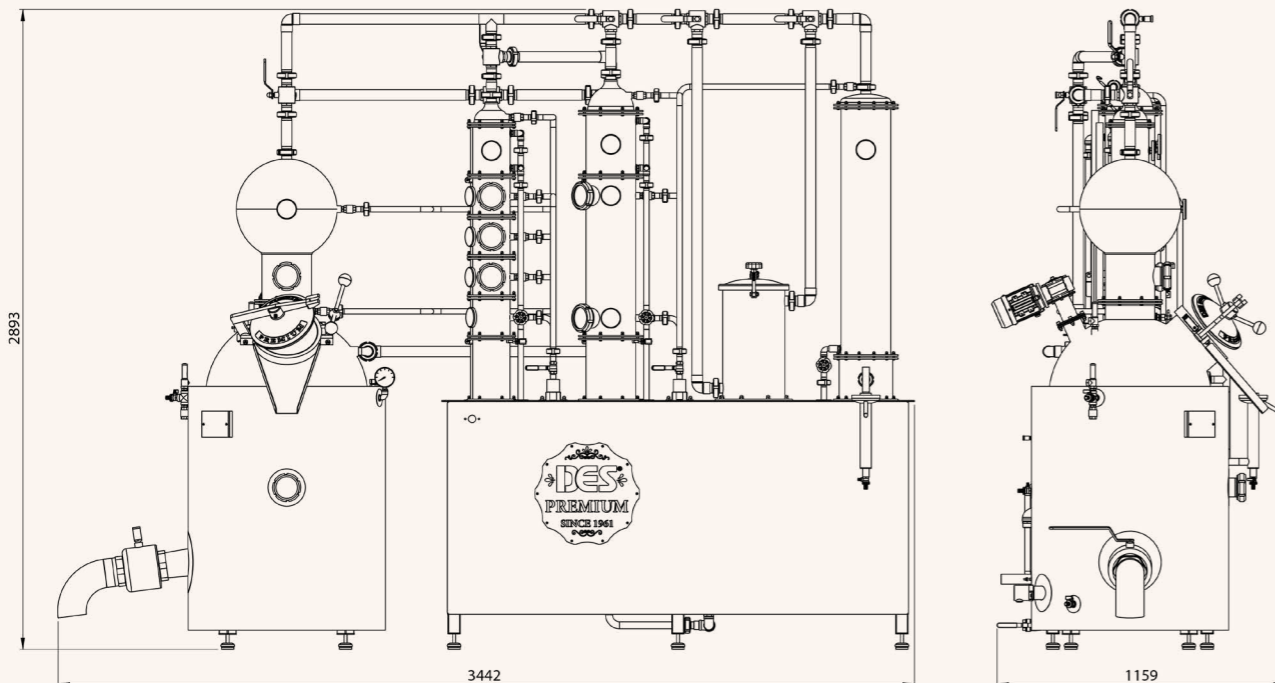

COMPONENTS

SPECIFICATIONS

Furnace material	Inox/Aisi 304 2 mm + (ceramic wool 25 mm + 1 mm brushed stainless steel)
Furnace working temperature	~110° C
Furnace working pressure	0.5 Bar
Heat source - electric heaters 2x9 kW	8-18 kW/h
Heat source - gas burner butane/natural 30-50 kW	4.72 kg/h-6.5 m ³ /h
Net capacity	200 L
Still material	Cu DHP/2 mm
Still cap - Alembic	Cu DHP/2 mm
Aroma Max column	Cu DHP/2 mm
Bubble plate column	Cu DHP/2 mm
Dephlegmator	Cu DHP/2 mm
Connecting pipes	Aisi 304 Ø40 mm × 1.5 mm
Cooling system	Aisi 304 Ø200 mm, shell 1 mm
Control unit	Manual setup
Vertical mixer - continuous 96 RPM	0.37 kW
CIP cleaning system	11 units + number of added column segments
Bypass system/by3V valve(s)	7 pieces
Aroma basket	10 L
Manufacturer's warranty	2 years

PREMIUM COLUMN STILL 200 L AROMA MAX COLUMN, BUBBLE PLATE COLUMN AND COLUMN WITH COPPER FILLING



Inlet opening



Drain opening



CIP cleaning system



Alembic, whisky or onion cap



Aroma Max or bubble plate column



Electric, gas, solid fuel or steam heating

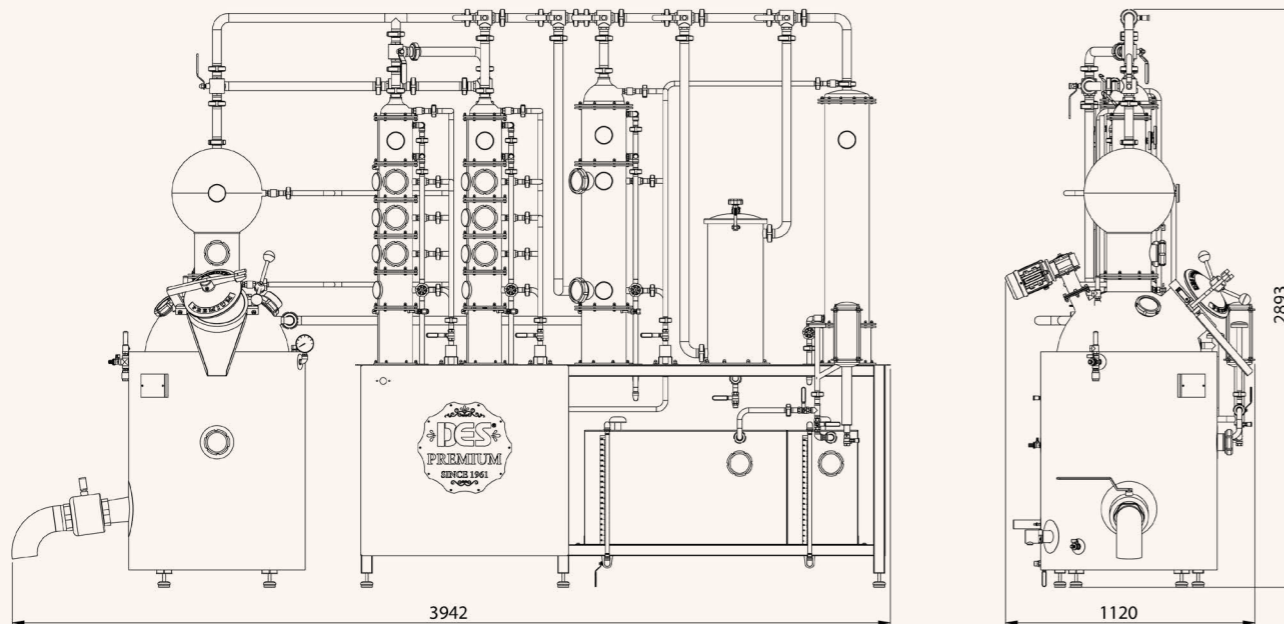

COMPONENTS	SPECIFICATIONS
Furnace material	Inox/Aisi 304 2 mm + (ceramic wool 25 mm + 1 mm brushed stainless steel)
Furnace working temperature	~110° C
Furnace working pressure	0.5 Bar
Heat source - electric heaters 2x9 kW	8-18 kW/h
Heat source - gas burner butane/natural gas 30-50 kW	4.72 kg/h-6.5 m ³ /h
Net capacity	200 L
Still material	Cu DHP/2 mm
Still cap - Alembic	Cu DHP/2 mm
Aroma Max column	Cu DHP/2 mm
Bubble plate column	Cu DHP/2 mm
Copper filling column	Cu DHP/2 mm
Dephlegmator	Cu DHP/2 mm
Connecting pipes	Aisi 304 Ø40 mm × 1.5 mm
Cooling system	Aisi 304 Ø200 mm, shell 1 mm
Control unit	Manual setup
Vertical mixer - continuous 96 RPM	0.37 kW
CIP cleaning system	16 units + number of added column segments
Bypass system/by 3V valves	9 pieces
Aroma basket	10 L
Manufacturer's warranty	2 years

PREMIUM COLUMN STILL 500 L AROMA MAX COLUMN



Inlet opening



Drain opening



CIP cleaning system



Alembic, whisky or onion cap



Aroma Max or bubble plate column



Electric, gas, solid fuel or steam heating

COMPONENTS

SPECIFICATIONS

Furnace material	Inox/Aisi 304 2 mm + (ceramic wool 25 mm + 1 mm brushed stainless steel)
Furnace working temperature	~110° C
Furnace working pressure	0.5 Bar
Heat source - electric heaters 4x9 kW	27-36 kW/h
Heat source - gas burner butane 25-110 kW	4.25 kg/h
Heat source - gas burner natural gas 25-110 kW	10.62 m ³ /h
Net capacity	500 L
Still material	Cu DHP/3 mm
Still cap - Alembic	Cu DHP/2 mm
Aroma max column	Cu DHP/2 mm
Dephlegmator	Cu DHP/2 mm
Connecting pipes	Aisi 304 Ø63 mm × 1.5 mm
Cooling system	Aisi 304 Ø300 mm, shell 1.5 mm
Control unit	Manual setup
Vertical mixer - continuous 96 RPM	0.55 kW
CIP cleaning system	6 units
Bypass system/by3V valve(s)	4 pieces
Aroma basket	30 L
Manufacturer's warranty	2 years

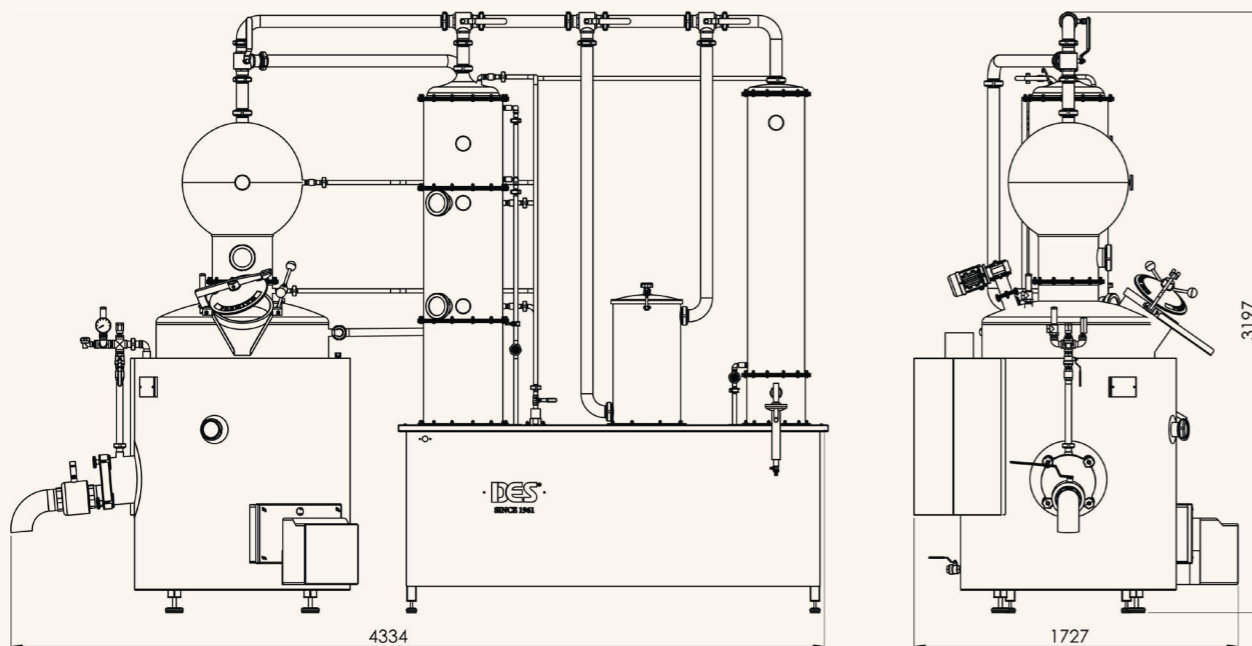

PREMIUM COLUMN STILL 500 L BUBBLE PLATE COLUMN



Inlet opening



Drain opening



CIP cleaning system



Alembic, whisky or onion cap



Aroma Max or bubble plate column



Electric, gas, solid fuel or steam heating

COMPONENTS

SPECIFICATIONS

Furnace material	Inox/Aisi 304 2 mm + (ceramic wool 25 mm + 1 mm brushed stainless steel)
Furnace working temperature	~110° C
Furnace working pressure	0.5 Bar
Heat source - electric heaters 4x9 kW	27-36 kW/h
Heat source - gas burner butane 25-110 kW	4.25 kg/h
Heat source - gas burner natural gas 25-110 kW	10.62 m ³ /h
Net capacity	500 L
Still material	Cu DHP/3 mm
Still cap - Alembic	Cu DHP/2 mm
Bubble plate column	Cu DHP/2 mm
Dephlegmator	Cu DHP/2 mm
Connecting pipes	Aisi 304 Ø63 mm × 1.5 mm
Cooling system	Aisi 304 Ø300 mm, shell 1.5 mm
Control unit	Manual setup
Vertical mixer - continuous 96 RPM	0.55 kW
CIP cleaning system	8 units + number of added column segments
Bypass system/by3V valve(s)	4 pieces
Aroma basket	30 L
Manufacturer's warranty	2 years

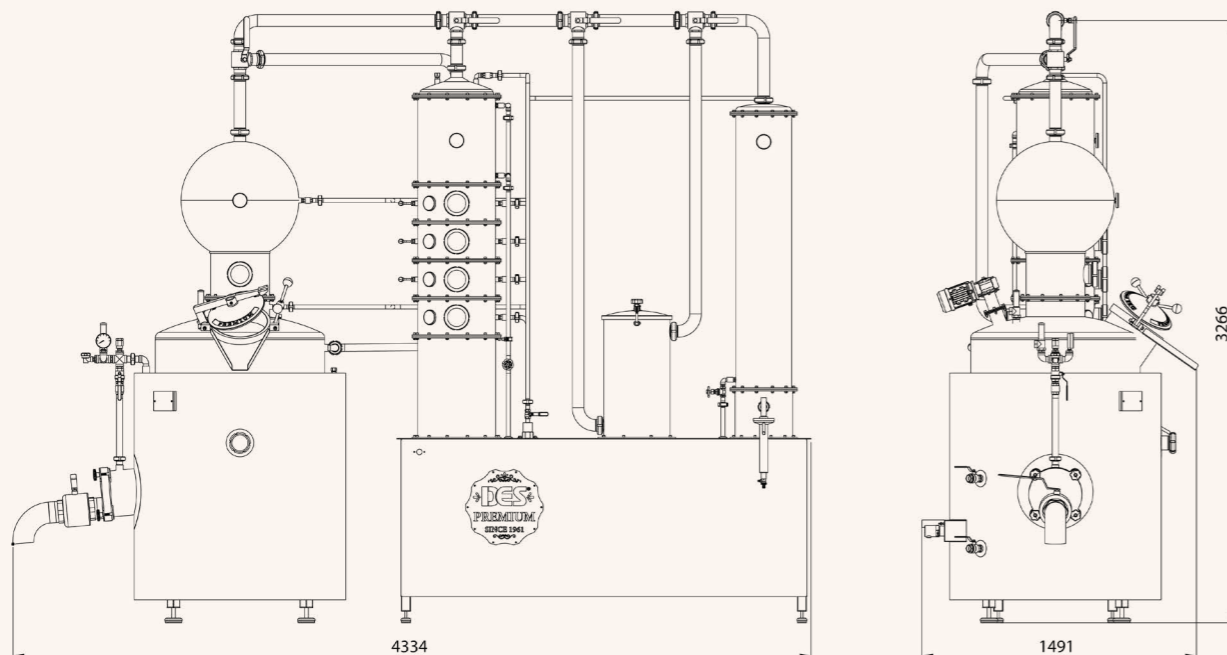

PREMIUM COLUMN STILL 500 L 2 COLUMNS WITH 10 BUBBLE PLATES

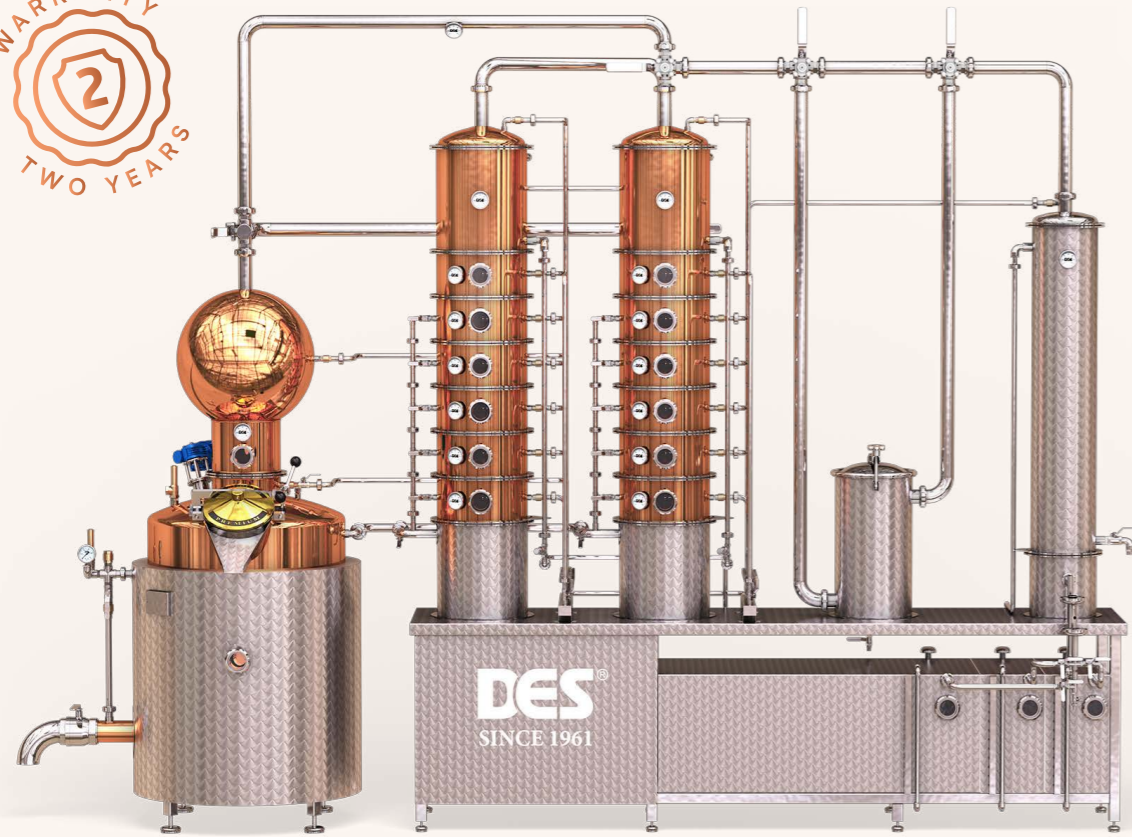

Inlet opening



Drain opening



CIP cleaning system



Alembic, whisky or onion cap



Aroma Max or bubble plate column



Electric, gas, solid fuel or steam heating

COMPONENTS

SPECIFICATIONS

Furnace material	Inox/Aisi 304 2 mm + (ceramic wool 25 mm + 1 mm brushed stainless steel)
Furnace working temperature	~110° C
Furnace working pressure	0.5 Bar
Heat source - electric heaters 4x9 kW	27-36 kW/h
Heat source - gas burner butane 25-110 kW	4.25 kg/h
Heat source - gas burner natural gas 25-110 kW	10.62 m ³ /h
Net capacity	500 L
Still material	Cu DHP/3 mm
Still cap - Alembic	Cu DHP/2 mm
Bubble plate column	Cu DHP/2 mm
Dephlegmator	Cu DHP/2 mm
Connecting pipes	Aisi 304 Ø63 mm × 1.5 mm
Cooling system	Aisi 304 Ø300 mm, shell 1.5 mm
Control unit	Manual setup
Vertical mixer - continuous 96 RPM	0.55 kW
CIP cleaning system	17 units + number of added column segments
Bypass system/by3V valve(s)	7 pieces
Aroma basket	30 L
Manufacturer's warranty	2 years

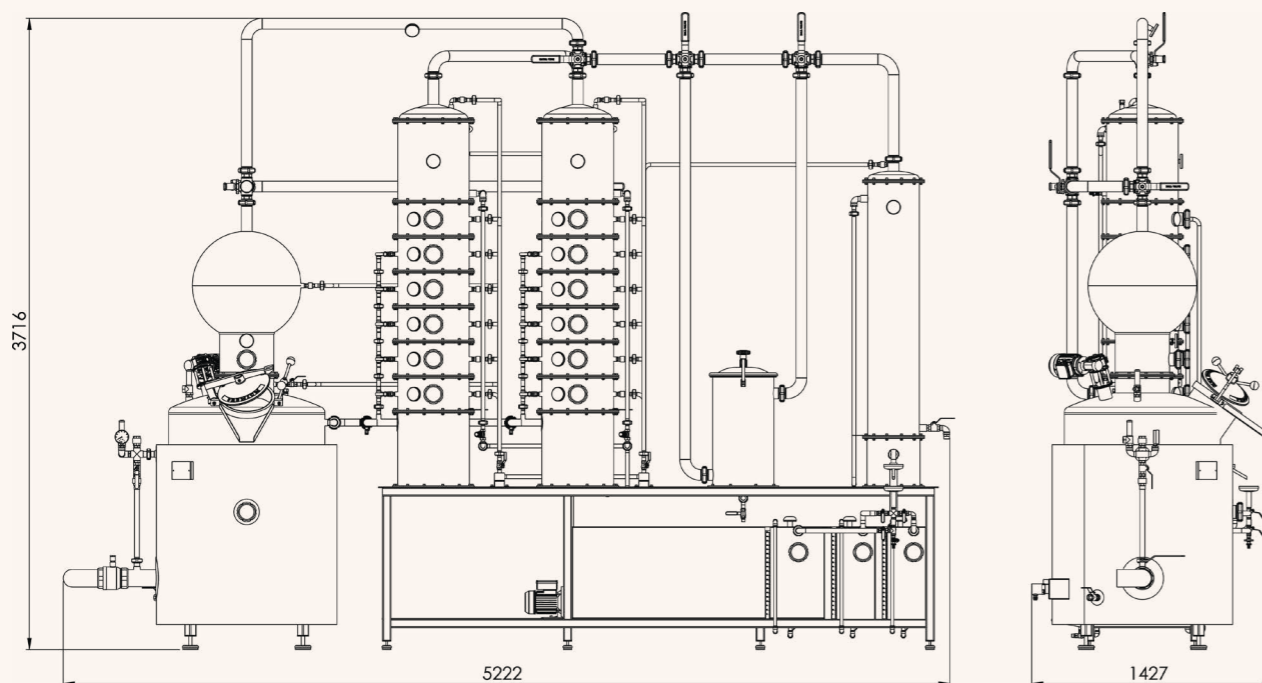

PREMIUM COLUMN STILL 500 L AROMA MAX AND BUBBLE PLATE COLUMN

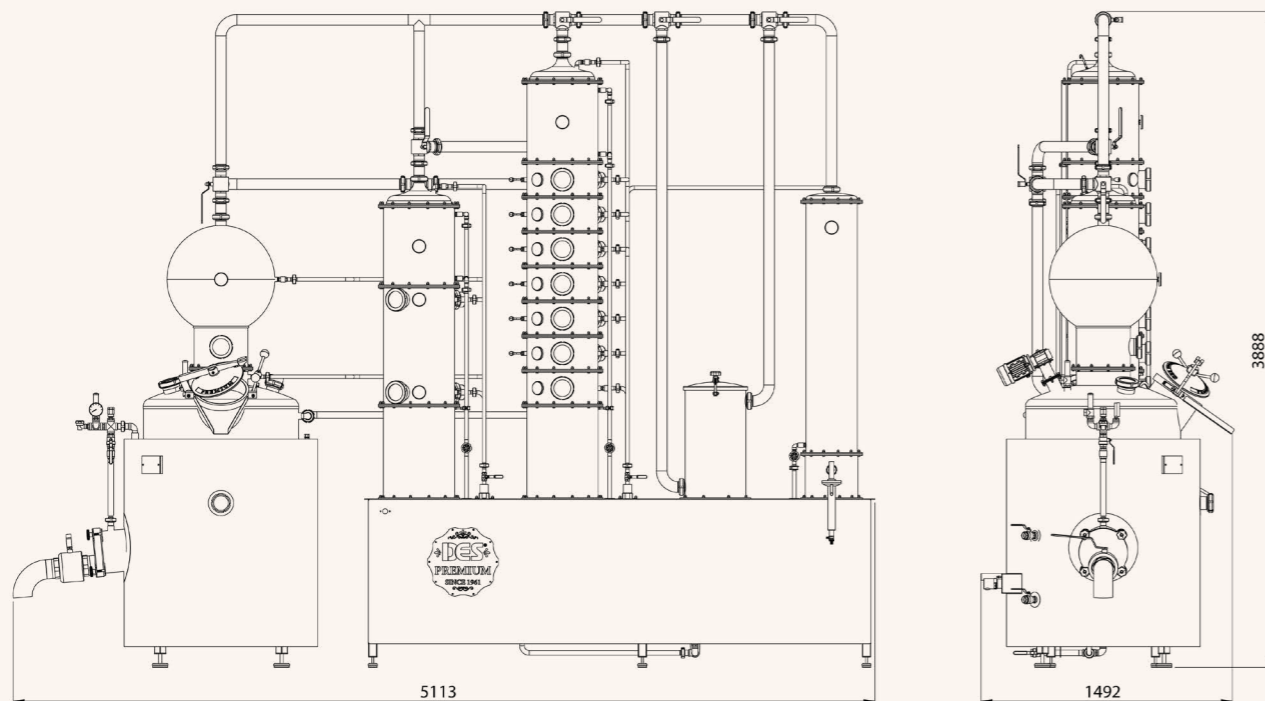

Inlet opening



Drain opening



CIP cleaning system



Alembic, whisky or onion cap



Aroma Max or bubble plate column



Electric, gas, solid fuel or steam heating

COMPONENTS

SPECIFICATIONS

Furnace material	Inox / Aisi 304 2 mm + (ceramic wool 25 mm + 1 mm brushed stainless steel)
Furnace working temperature	~110° C
Furnace working pressure	0.5 Bar
Heat source - electric heaters 4x9 kW	27-36 kW/h
Heat source - gas burner butane 25-110 kW	4.25 kg/h
Heat source - gas burner natural gas 25-110 kW	10.62 m ³ /h
Net capacity	500 L
Still material	Cu DHP/3 mm
Still cap - Alembic	Cu DHP/2 mm
Aroma Max column	Cu DHP/2 mm
Bubble plate column	Cu DHP/2 mm
Dephlegmator	Cu DHP/2 mm
Connecting pipes	Aisi 304 Ø63 mm × 1.5 mm
Cooling system	Aisi 304 Ø300 mm, shell 1.5 mm
Control unit	Manual setup
Vertical mixer - continuous 96 RPM	0.55 kW
CIP cleaning system	14 units + number of added column segments
Bypass system/by3V valve(s)	7 pieces
Aroma basket	30 L
Manufacturer's warranty	2 years

PREMIUM COLUMN STILL 2×500 L AROMA MAX COLUMN



Inlet opening



Drain opening



CIP cleaning system



Alembic, whisky or onion cap



Aroma Max or bubble plate column



Electric, gas, solid fuel or steam heating

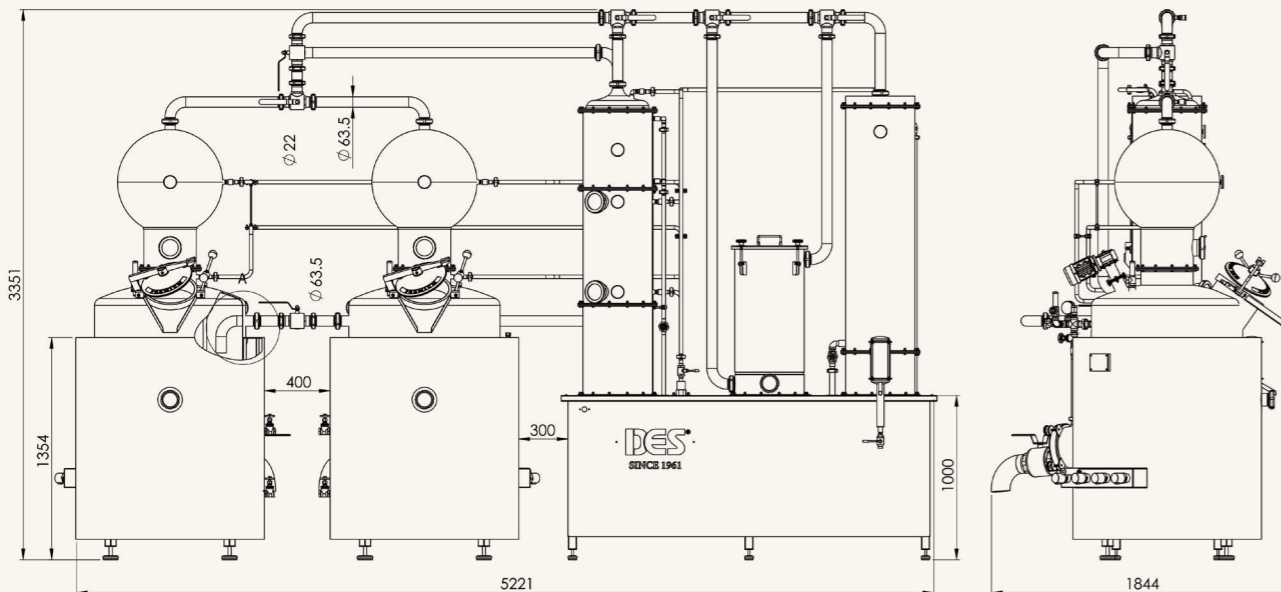

COMPONENTS

SPECIFICATIONS

Furnace material	Inox / Aisi 304 2 mm + (ceramic wool 25 mm + 1 mm brushed stainless steel)
Furnace working temperature	~110° C
Furnace working pressure	0.5 Bar
Heat source - electric heaters 4×9 kW	2×27-36 kW/h
Heat source - gas burner butane 25-110 kW	2×4.25 kg/h
Heat source - gas burner natural gas 25-110 kW	2×10.62 m ³ /h
Net capacity	2×500 L
Still material	Cu DHP/3 mm
Still cap - Alembic	Cu DHP/2 mm
Aroma Max column	Cu DHP/2 mm
Dephlegmator	Cu DHP/2 mm
Connecting pipes	Aisi 304 Ø63 mm × 1.5 mm
Cooling system	Aisi 304 Ø422 mm, shell 1.5 mm
Control unit	Manual setup
Vertical mixer - continuous 96 RPM	2×0.55 kW
CIP cleaning system	8 units
Bypass system/by3V valve(s)	6 pieces
Aroma basket	80 L
Manufacturer's warranty	2 years

PREMIUM TRADITIONAL POT STILL 1000 L



Inlet opening



Drain opening



CIP cleaning system



Alembic, whisky or onion cap



Double wall



Steam heating

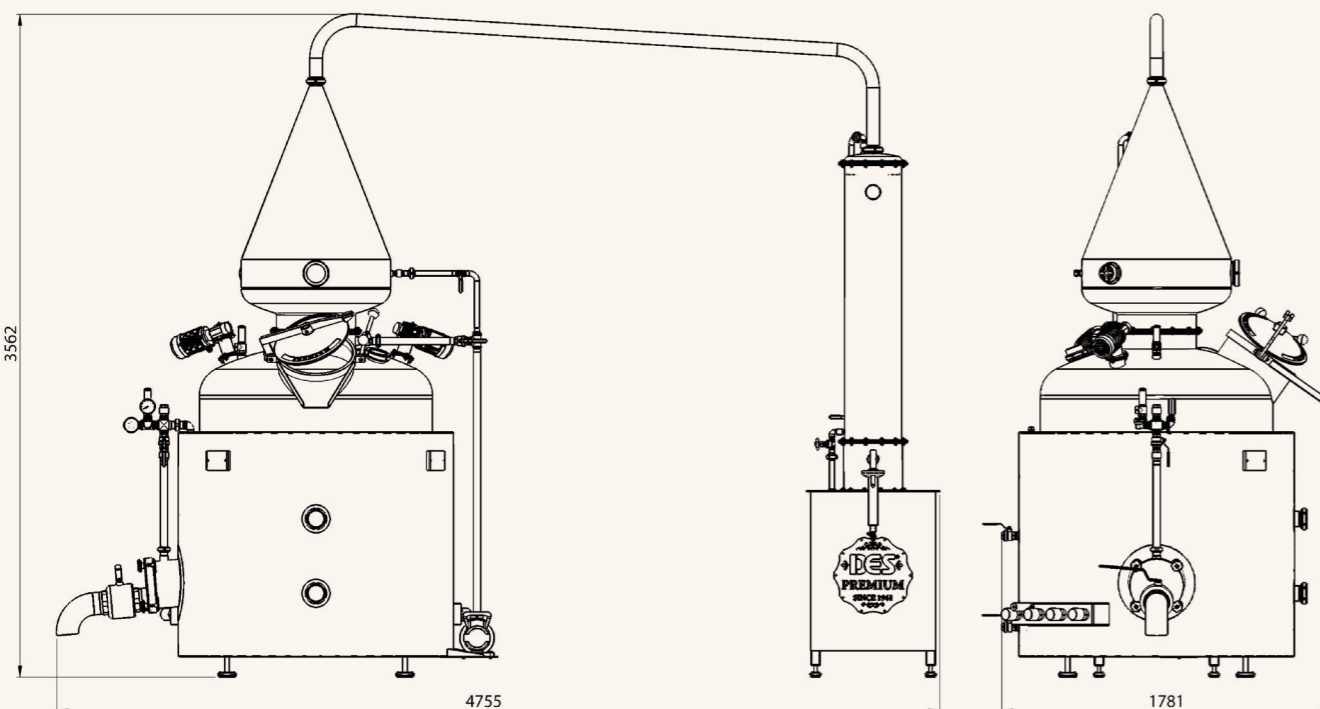

COMPONENTS	SPECIFICATIONS
Furnace material	Inox / Aisi 304 2 mm + (ceramic wool 25 mm + 1 mm brushed stainless steel)
Furnace working temperature	~110° C
Furnace working pressure	0.5 Bar
Heat source - electric heaters 8x9 kW	54-72 kW/h
Net capacity	1000 L
Still material	Cu DHP/5 mm
Still cap - Whisky	Cu DHP/3 mm
Connecting pipes	Aisi 304 Ø63 mm × 1.5 mm
Cooling system	Aisi 304 Ø422 mm, shell 1.5 mm
Control unit / semi automatic handling	Manual setup
Vertical mixer - continuous 96 RPM	2x0.55 kW
CIP cleaning system	3 units
Manufacturer's warranty	2 years

PREMIUM COLUMN STILL 2×3000 L AROMA MAX COLUMN



WARRANTY
2
TWO YEARS



Inlet opening



Drain opening



CIP cleaning system



Alembic, whisky or onion cap



Aroma Max or bubble plate column



Steam heating

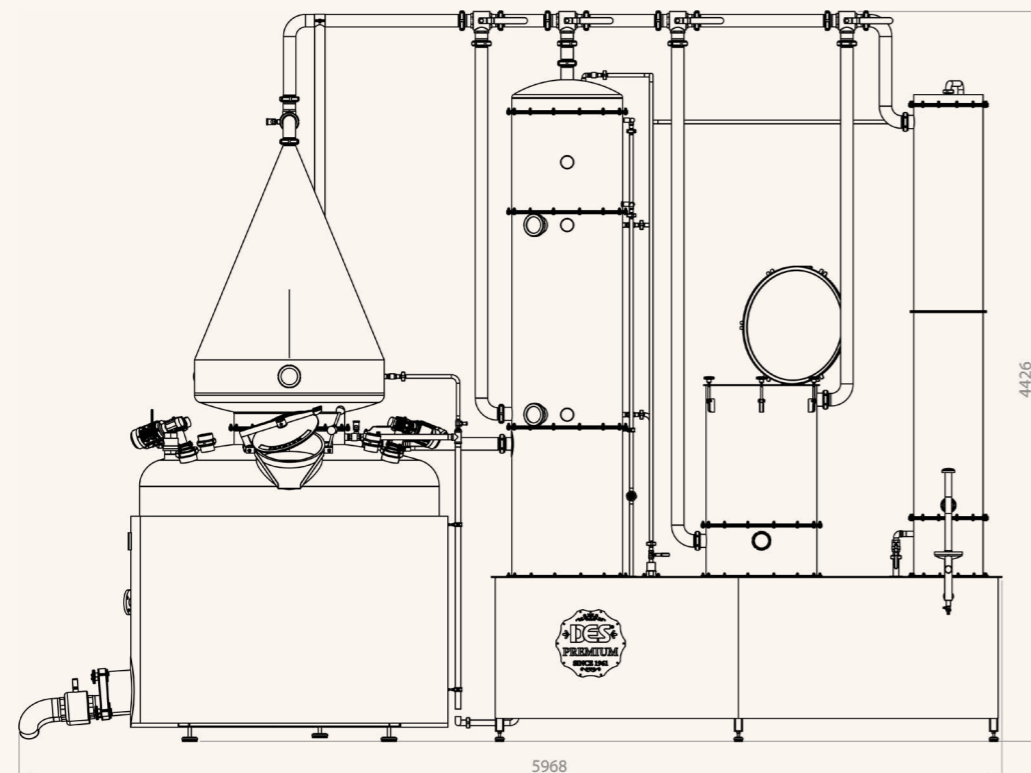

COMPONENTS

SPECIFICATIONS

Furnace material	Inox/Aisi 304 2 mm + (ceramic wool 25 mm + 1 mm brushed stainless steel)
Furnace working temperature	~170° C
Furnace working pressure	8 Bar
Net capacity	2×3000 L
Still material	Cu DHP/5 mm
Still cap - Whisky	Cu DHP/3 mm
Connecting pipes	Aisi 304 Ø76 mm × 1.5 mm
Cooling system	Aisi 304 Ø422 mm, shell 2 mm
Control unit	Manual setup
Vertical mixer - continuous 96 RPM	0.55 kW (2×2 pieces)
CIP cleaning system	8 units
Bypass system/by3V valve(s)	6 pieces
Aroma basket	200 L
Manufacturer's warranty	2 years

PREMIUM GRAPPA COLUMN STILL 300 KG BUBBLE PLATE COLUMN



Inlet opening



CIP cleaning system



Aroma Max or bubble plate column



Steam heating

COMPONENTS	SPECIFICATIONS
Furnace material	Ceramic wool 25 mm + 1 mm brushed stainless steel
Steam working temperature	~110° C
Steam working pressure	0,5 Bar
Heat source - steam	70 kg/h per pot
Net capacity	300 kg (700 L)
Still material	Cu DHP/3 mm
Still cover	Cu DHP/2 mm
Bubble plate column	Cu DHP/2 mm
Dephlegmator	Cu DHP/2 mm
Connecting pipes	Ø63 mm × 1.5 mm
Cooling system	Aisi 304 Ø422 mm, shell 2 mm
Control unit	Manual setup
CIP cleaning system	10 units + number of added column segments
Basket/sieve - 4 pieces	Perforated Aisi 304 - 3 mm
Tank for reflux	Aisi 304 - 3 mm
Drain for reflux	1"
Drain for condensation in the pot	2"
Bypass system/by3V valve(s)	1 for each pot added
Alcoholmeter holder	Aisi 304
Manufacturer's warranty	2 years

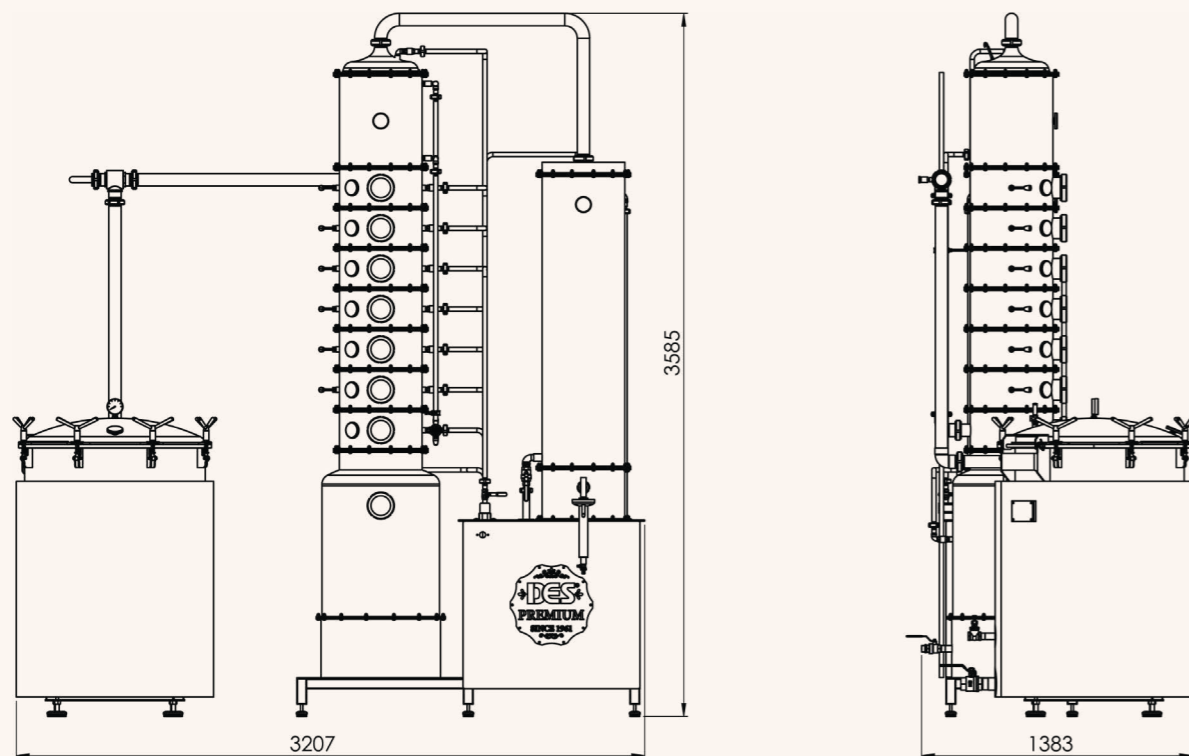

CUSTOMER CONFIGURATIONS ALL OVER THE WORLD

It is easy to buy a bottle of drink,
but it is a pleasure to make it by yourself.



DES® PREMIUM CUSTOMER REFERENCE LIST

Starting craft distilling is not a job, it is a lifestyle.
When you buy a pot still, it becomes a lifelong possession, but also stays with next generations.



ŠURLAN DISTILLERY

Novi Kozarci, Serbia

At the end of the last century, the Šurlan family from the Banat village of Novi Kozarci started their fruit growing business. Then they planted the first hectare with apple trees, not assuming how much their orchards would expand and multiply in the following decades. In the beginning, they grew fruit for their own needs and the needs of the local market, in time perfecting the technology for the preparation and production of top-quality domestic brandy. In 2003, they registered their distillery.

In the near future, it is planned to increase work capacity, open to new market networks and further penetrate into territories outside the borders of Serbia, according to GAP and HACCP norms.



Šurlan Distillery, in addition to the production of fruit brandy as its main product, also produces liquor of excellent taste. They offer brandies made from all kinds of fruit: plums, apricots, pears, apples, quinces, vines, cherries, raspberries and mead.

In order to modernize his production, the owner of the Šurlan Distillery, Darko, decided to purchase a DES premium model of 500 L with two different columns, aroma max and a column with bubble plate.

Pot still:

- 🌿 Premium column still 500 L Aroma Max and bubble plate column

Product range:

- 🌿 Bitters
- 🌿 Brandy



SVAROG DISTILLERY

Maribor, Slovenia

The Svarog family distillery is equipped with a new pot still, and the owners Bojan and Lidija are looking forward to modernizing the distillery and perfecting the recipe for their Svarog gin. Svarog, the God of the sky - the protogod represents the main deity of Slavic mythology. It signifies strength, courage and mystery, it connects heaven, earth and nature. All these and many other secrets distinguish the gin of the Svarog distillery. From carefully selected herbs of domestic production, this distillery produces spirits of the highest quality.

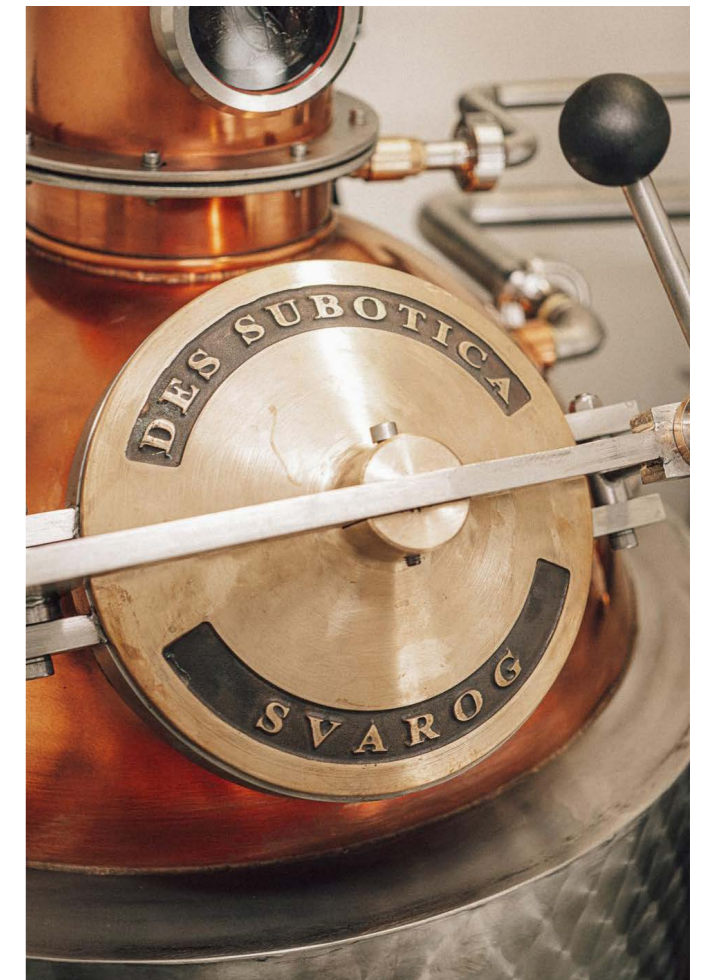

This device is popular with winemakers, small and medium craft distilleries. Definitely the best-selling product of the premium segment, the DES pot with a side column, and a capacity of 150 liters. The device was installed in the famous Slovenian Svarog distillery located in the vicinity of Maribor, where the owners will distill primarily gin and cognac, followed by brandy, rum and whiskey in their new toy.

Pot still:

- 🌿 Premium column still 200 L bubble plate column

Product range:

- 🌿 Gin



DAMIJANIĆ DISTILLERY

Pula, Croatia

Sette monti gin is the result of many years of imagination and the excellent story of a world bartender that adorns this distillate. Sette Monti translates as seven hills. The distillery is located in Pula. Like Rome, Pula is built on 7 hills, and guess how many ingredients this delicious gin has? Exactly 7! The bergamot bark from Sicily and the Persian rose, which is procured from Iran, are the spices that make their gin recognizable, and the other ingredients are procured locally, juniper from the slopes of Čičarija, coriander, chamomile, licorice, angelica root.

Karlo, the bartender and owner, chose a modern type of pot still with two side columns, 6 bubble plates, a capacity of 200 L, electric heating, a brass door engraved with the name of the distillery, a gin basket with a capacity of 10 L.



Karlo Damijanić, the owner of the Damijanić family distillery, has been building his career for eighteen years and is the owner of numerous awards and titles in the field of bartending and flair bartending. He won the National Championship three times representing Croatia at the World Championship where he won an enviable fourth place in Singapore in 2010.

Sette Monti gin entered the market in 2021, and already in the first year, it was decorated with gold medals, Gin of the year 2021 in London and Cro Agro 2021 in Zagreb, as well as bronze from the World Gin Awards.

Pot still:

- Premium column still 200 L
- 2 columns with bubble plates

Product range:

- Gin
- Brandy
- Teranino



LYNX CRAFT DISTILLERY

Gorski Kotar, Croatia

Marin Mihaljević Žulj is a doctor of biotechnical sciences and a professor of strong alcoholic beverages at the University of Zagreb. Enthusiast of distillation. In his free time, he fires up his merry machine and like Professor Baltazar waits for the perfect drop to flow.

Maja Žulj Mihaljević is a doctor of biotechnical sciences who replaced a successful scientific career with entrepreneurship, in the desire for freedom, meaning and more time for what she really loves - family and plants. Either for eating, fermentation or maceration.



Lynx liquor is magical - it was created by the maceration of 13 plant species, with an emphasis on wormwood, but also other mountain plants, such as gentiana lutea, giving it a seductive complexity.

Pot still:

- Premium column still 200 L
- Aroma Max column on top

Product range:

- Gin
- Bitters



GINSANITY DISTILLERY

Cologne, Germany

How did the idea for gin production come about? The owners of the GINsanity distillery, Dagmar and Michael Frangenberg, located in Keln, have been lovers of gin for 20 years. Dagmar worked as a TV writer abroad, and Michael as a purchasing director in the company. After each trip, they brought back gins that they admired together, so the idea was born that they should also try to produce their first gin.



In their 40s, they bought a mini pot still, visited distilleries, went to many trainings, and started their adventure. They produce raspberry gin, classic, orange, chocolate, white truffle, lime, coffee, as well as non-alcoholic gin. Very quickly, the world's biggest awards started to come. Pot still 200 L with gin basket, and electric heating is the first premium DES pot still to appear on the German market.

Pot still:

🌿 Premium traditional still 200 L

Product range:

- 🌿 Gin
- 🌿 Gin-Liqueur



FERMENTHINKS DISTILLERY

Florence, Italy

Fermenthinks was born - a distillery, a laboratory and a machine of ideas that aims to create artisanal and quality products, even for small businesses and in sustainable quantities.

Stefano, Julian, Matthew, three young "Spirits Cowboys" were very successful in bartending so they decided to start their own business. The main product is gin and liquor. They offer a complete service - research, development, production, bottling and labelling. London Dry Gin is their forte; it's finer and purer, and harnesses the versatility of the buffalo still, a stunning 200 litre alembic that reigns supreme in our headquarters and never stops working.



Why "spirit cowboys"? We've embarked on an adventure in uncertain times, exploring new frontiers, making gin and spirits as private labels in the first urban distillery in the hills near Florence. How did they choose the name Fermenthinks? The name of the distillery Fermenthinks comes from two words between "ferments" and "thinks" = thoughts in ferment.

Pot still:

🌿 Premium traditional still 200 L

Product range:

- 🌿 Whisky
- 🌿 Gin



RAME DISTILLERY

Perugia, Italy

Rame, the artisanal distillery that captures the soul of Italy in the heart of Perugia. From the slopes of the Umbrian hills, Rame rises, a laboratory of passion and mastery. Our artisans dedicate every moment to creating spirits of the highest quality, using only carefully selected ingredients and a technique passed down through generations. In 2023 Rame, Distilleria Perugia Urbana, was born, a micro artisanal distillery that produces spirits such as fernet, liqueur, London dry gin, vodka, and bitter with a 200 L electric still with gin basket capacity of 30 L.



In the heart of the historic center of Perugia, above the acre of the medieval aqueduct, along Via Appia, stands the distillery, where it is possible to visit the cellar, the production laboratory and taste high-quality cocktails, craft beers, natural wines and selected food.

Pot still:

- 🌿 Premium traditional still 200 L

Product range:

- 🌿 Vodka
- 🌿 Gin
- 🌿 Fernet
- 🌿 Liqueur



ZONA B DISTILLERY

Verona, Italy

After 7 years of working in a craft brewery, in 2022, Alessandro Zaghi decided to open the first gin distillery in the province of Verona. ZONA B symbolizes the initial names of family members, and the pot is named Oscar after his son's name. The ZONA B distillery uses a DES alembic pot with a double wall, with a capacity of 200 liters. This device has 2 side columns, and each column contains 3 bubble plates, which opens up many different options for the owners of this distillery to produce more types of alcoholic beverages.

A terpene gin is named after the natural compounds that give plants their special smells and tastes. Alessandro uses organic alcohol and Italian herbs for his product: in addition to essential juniper, coriander and angelica, his gin contains licorice, chamomile, cardamom and citrus.



A week after Alessandro tasted the first Italian gin, he bought a 2 L pot still and began experimenting with the production of alcoholic beverages in his home. Not long after that, he started searching for the perfect place for his distillery and a device that would enable the realization of his every idea. Considering that you are reading this text about Zona B Distillery in the DES premium reference list, it is clear how his search ended.

Pot still:

- 🌿 Premium column still 200 L
- 2 columns with bubble plates

Product range:

- 🌿 Gin



VÄSTERÅS DISTILLERY

Västerås, Sweden

Västerås Destilleri is one of the fastest growing distilleries in Sweden. Salar and Emmelie founded Västerås Destilleri AB. Salar has worked as a bartender for 8 years and is particularly passionate about gin. Emmelie is a trained chef since 13 years ago, but has worked as a pastry chef for the last 6 and has an extra sense of taste.

Their gin has won three Masters medals at Global Gin Masters 2024, their very first participation in the competition.



At the heart of the distillery is Västerås Dry Gin, distilled with NGS from Swedish winter wheat, juniper, coriander seeds, angelica root, fresh lemon peel, elderflower, black Tellicherry pepper, Damascus rose and barberry. Also in their product portfolio: Västerås Pink Gin, to which natural pomegranate seeds are added for color after distillation, giving it a subtle berry flavor, and Västerås Navy Strength and Västerås Gimlet, a ready-to-drink beverage in a bottle of gin, sugar and lime.

Pot still:

- Premium column still 200 L
bubble plate column

Product range:

- Gimlet
- Gin



LYDÉN DISTILLERY

Ljungby, Sweden

Lydén Distillery is a craft distillery located in Sweden. Founded in 2019, by Roger & Emil Lydén, Father and son with a common interest - Swedish Craft Gin. Their Gin is produced in small batches with carefully selected organic botanicals. The craftsmanship makes each batch and bottle unique.

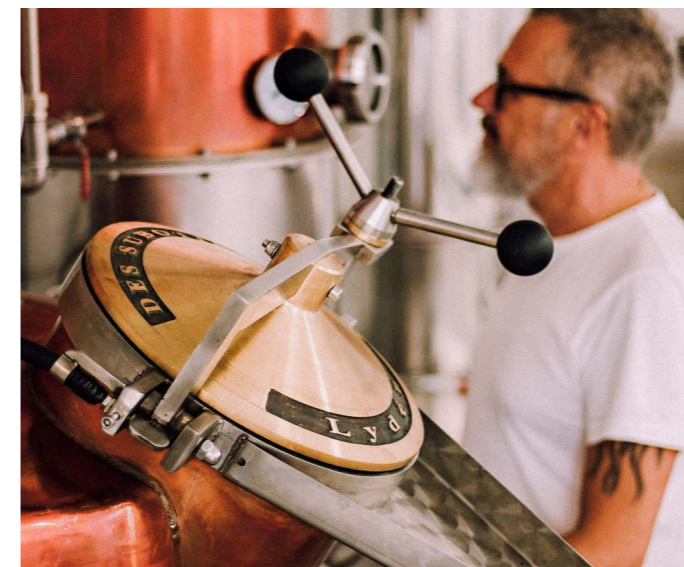

"A powerful, fragrant nose with resinous pine, green herbs, chamomile, white grapefruit, and meadow grass. The palate is well balanced with a fantastic oiliness, warm spice, earthy juniper, and the cut of grapefruit acidity. Some orange and pepper notes in the finish. Super balance and control of flavors and complexity." Lydén Distillery's 2021 London Dry Gin has won award for the best gin in the world and it was made in DES aroma max pot still!

Pot still:

- Premium column still 500 L
Aroma Max column

Product range:

- Gin



BLACK POWDER DISTILLERY

Witton, Great Britain

Flintlock Navy Strength Gin - Traditionally styled London Dry Gin, and then some! Unashamedly old school, with a judicious streak of juniper running through it, the depth and complexity of flavour here is staggering and staggeringly good! Bitter orange, clove, rooty woods & deep spices and despite its high alcohol levels the alcohol is exceptionally well integrated, leaving a smooth mellowness on the palate. A gin-lover's gin, made by a masterful savant. Utterly outstanding.



Situated in the picturesque countryside and overlooking the coastal peninsula of Western Lancashire resides one of the most unique and diverse distilleries in the region. Black Powder offers an extensive range of exciting products, all meticulously handmade in traditional copper pot stills. Along with gins judged to be some of the finest in the world, they also produce exquisite liqueurs, rums, whiskey, port and over 40 delicious and entirely natural fruit gins to tantalise all taste-buds.

Pot still:

🌿 Premium traditional still 500 L

Product range:

- 🌿 Gin
- 🌿 Liqueur
- 🌿 Rum
- 🌿 Whisky



NORTH POINT DISTILLERY

Thurso, Scotland

They create small batches of authentic Scottish spirits and they distill them in the most interesting way. After using the very finest and sustainably sourced sugarcane and molasses from the Caribbean, they use local whisky casks from the Scottish Highlands to mature and finish their spirit. Just like the pilots, they are prepared to go to the ends of the world to help their community and business be the best that can be. They believe in the beautiful far north of Scotland. Also, they believe in their products. And they believe in providing their customers with the highest quality, locally-distilled spirits they can create.

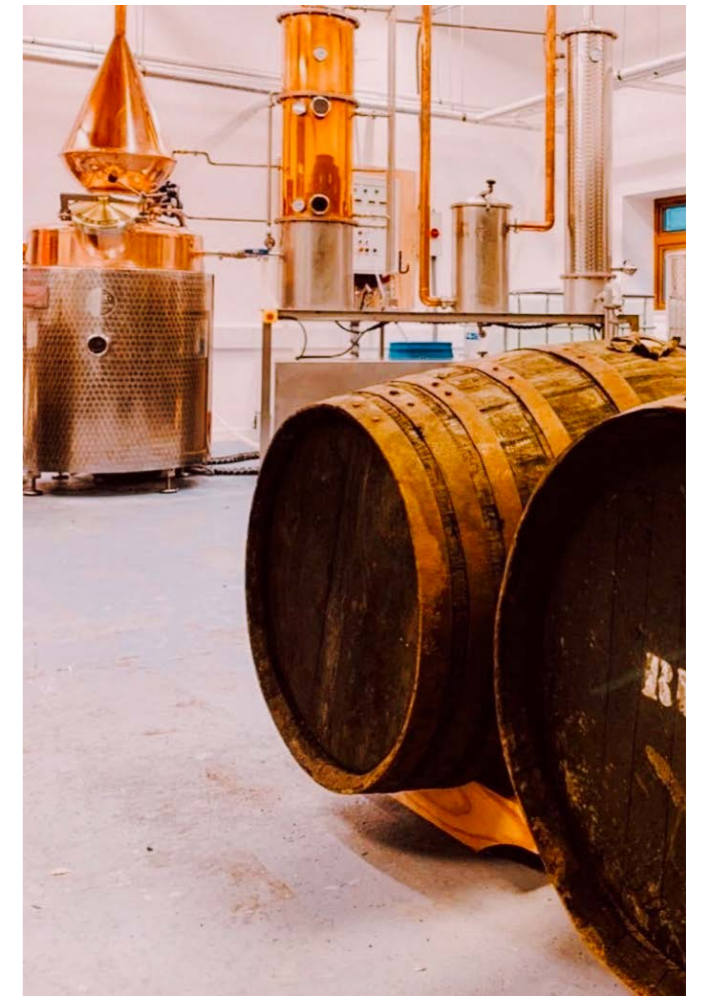

Stroma is an island off Caithness. It used to be home for fishermen, crofters and, you guessed it, the pilots. Slowly people left the island and in 1997, the remaining residents (the lighthouse keepers and their family) moved out too, leaving it uninhabited... The island is now owned by a family who use it to graze sheep - very lucky sheep we'd say! Sandy Stroma is as unique as the spirits it produces. In the Scotland Highlands, this copper still called Stroma is doing her magic now. Her new owners at North Point Distillery are excited to do the experiments and make a high-quality rum, gin, and brandy with this whisky helmet, brandy, and rum column, as well as a botanical gin basket.

Pot still:

🌿 Premium column still 500 L
Aroma Max column

Product range:

- 🌿 Rum
- 🌿 Whisky
- 🌿 Gin



ATELIER-CONSTANTBERGER DISTILLERY

Herve, Belgium

The fruit brandies are produced from fruits from high-stem orchards in the Liège region. They bought 2 stills, in the first still an alcohol at +/-30° was distilled. Thanks to the second still they distilled an alcohol at 70°. During the second distillation the know-how of Léandre, the maestro distiller comes into play! He must indeed smell and taste what comes out of the still to keep only the heart of distillation which contains the perfect aromas! The alcohol is therefore ready to be aged for at least 6 months.



Adeline and Léandre meet at the end of their studies, later Léandre discovered the secrets of distillation at the Juniper Museum and then began training in distillation in Hasselt. He learned to distil all fermentable materials and dreamed of producing not only Juniper, but spirits, whisky, etc. The couple want to reinvent the micro-distillery. In the tradition of vintage distillers, they want to make distillation accessible to everyone by making their know-how and their machines available.

Pot still:

- 🌿 Premium traditional still 500 L
- 🌿 Premium traditional still 200 L

Product range:

- 🌿 Brandy
- 🌿 Juniper Spirits
- 🌿 Whisky



ANAIAK DISTILLERY

Ciboure, France

Launched in 2020, Anaiak Gin is produced by brothers Rémy and Boris Harretche at their distillery in a renovated garage in the town of Ciboure, and the name "Anaiak" means "brothers" in Basque language. The base spirit is produced with organic grape marc from the Bordeaux region and the lemon verbena and eucalyptus botanicals are picked locally in the Basque region. Their custom built 120 liter reflux still was designed solely for making gin. In 2023 the distillery's second gin was launched, Gin Fraternel N2.

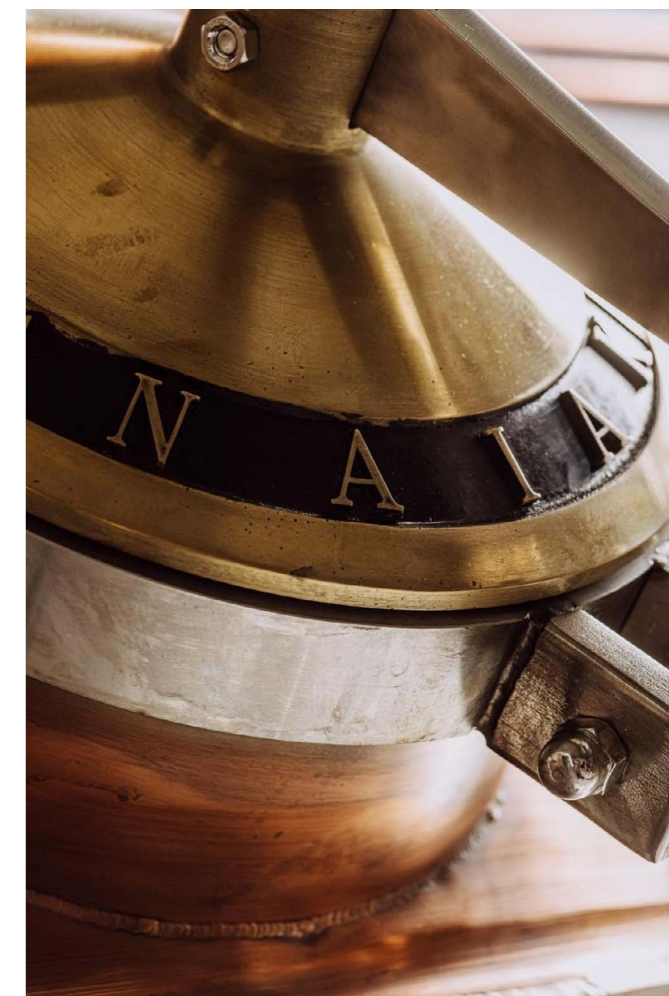

In 2021, as part of The Gin Guide Awards competition, Anaiak gin received the distinctions of "Best in France" and "Highly Commended". Anaiak Gin characterfully combines fresh, clean and herbal notes with juniper and earthy, aromatic spice, delivered with balance and cohesion, while the grape marc base spirit brings wonderful body and a generous mouthfeel. Anaiak is a balanced gin with 41% alcohol.

Pot still:

- 🌿 Premium traditional still 200 L

Product range:

- 🌿 Gin



MEZENK DISTILLERY

Saint-Jeures, France

Mezenk, the French distillery is located in the mountains of Auvergne at an altitude of 900 m and is named after the mountain Mont Mezenk. All the plants that the owners use for the production of gin are sourced locally from Mezenk Mountain. The water used comes from volcanic rocks, it is mineralized through an uncontaminated geological base, unique in its diversity. It is an understatement to say that we are delighted with the environment in which this distillery is located.



Owner Jacques produces gin, rum, whisky, absinthe, and vodka in his new pot still. His choice is a 500 L device with an Aroma max column, electric heating and solid fuel, with a gin basket. The combination of electricity and solid fuel is excellent for all those who have a large amount of firewood that can provide savings in consumption. In addition to this pot, for experimentation and recipe research, Jacques uses a DES Performance hobby still with a capacity of 100 L. The complete distillery is made of stone, the impression is phenomenal.

Pot still:

- Premium column still 500 L Aroma Max column

Product range:

- Whisky
- Gin
- Absinthe
- Rum
- Vodka



LE VADROUILLEUR DISTILLERY

Sault, France

The idea behind Le Vadrouilleur Distillery is to provide the market with quality craft spirits with organic raw materials and ingredients. Most importantly, caring for the environment is a key thing that sets this distillery apart. Most of the raw materials they use come from within a 20 km radius and are produced in France. The aim is to showcase France's beautiful Provence region, which contains enchanting landscapes and wondrous botanicals. The distillery is located in the lavender capital of Sault. This place is dominated by beautiful lavender fields.



Their Mistello gin is based on locally sourced botanicals, focusing on organic lavender. Nevertheless, this gin contains floral notes, while the mouthfeel develops complex aromas of citrus and warm spices. The hybrid 500 L pot still with two side columns, a column with bubble plates and an Aroma max column is responsible for all of this, while for additional aromatization, a gin basket has been installed that further enriches the distillate.

Pot still:

- Premium column still 500 L Aroma Max and column with bubble plates

Product range:

- Gin
- Liqueur



3 CITY DISTILLERY

Sopot, Poland

In northern Poland, on the Baltic coast in Sopot - Marta and Howard Chaganis founded 3 City Distillery, where quality always comes before quantity. Their premium London Dry gin carries a local signature: among the botanicals is juniper sourced from the Baltic coast, which adds freshness and a clean, elegant taste. The result is exceptionally drinkable gin, bright, and naturally made for tonic - exactly how a London Dry should behave in the glass. At the heart of their production is a 200-liter, all-copper DES still, chosen not only for its looks but for what copper does in the process: superior heat conductivity, a cleaner, richer flavour, and a reduction of potential impurities. Each distillation is done patiently and precisely - the heat-up is gradual, the first drops appear after about two hours, and the run finishes in roughly seven and a half hours, yielding a batch of around 350 bottles.



Marta and Howard came to DES on the recommendation of fellow distillers and highlight our excellent communication, delivery times, and quality that, as they say, exceeds expectations for the price. The distillery is open for private tours and tastings by appointment.

Pot still:

- All copper premium traditional 200 L

Product range:

- Gin



TESSELLIS DISTILLERY

Sosnowiec, Poland

At the beginning of the twentieth century, three close friends came up with an ambitious plan to establish their own distillery in Poland. Three years and two uprisings later, their plan matured and the dream finally became a reality. Inside the workshop, the space was gradually filled with the magical aromas of juniper and various plants. In the end, the market got a new player - Tessellis Distillery, which brought with it the perfect recipes for making London dry gin and a new version of vodka. Unfortunately, due to the unfortunate circumstances of the war, the distillery had to close its doors. So, the owners carefully wrote down their precious recipes in the "Book of Alchemy," which they buried deep in the outskirts of the city. This book withstood the challenges of war, communism and the time of the Polish People's Republic.



After many years, someone finally found this invaluable collection of recipes, allowing Tessellis gin and vodka to be back on the market, now, made in a DES three-fraction column still. Tessellis is a word that comes from Latin, it means mosaic. It is a kind of metaphor that refers to the production of gin, botanical vodka and other strong spirits. The quantities and types of plants must be perfectly coordinated so that they harmonize with each other and create unity.

Pot still:

- Premium column still 200 L bubble plate column

Product range:

- Vodka
- Gin
- Absinth



AARAU DISTILLERY

Aarau, Switzerland

Michael Stampfli, Urs Lüthy, Jean Hächler are the owners of a small distillery in the Swiss town of Aarau. They decided on a DES pot with a capacity of 200 L with a side column and a basket for gin, electric heating. They mostly produce gin, but they recently added absinthe to their range. Monkey in a bottle gin got its name from one of the ingredients used in the production of this gin, the fruit of the baobab tree, whose fruit is loved by monkeys. The best-sellers are London dry gin, New Western gin (fruity) and autumn gin, aged in a barrel for 2-6 months.



Gold Edition goes well with a citrus tonic. And our recommendation is a gin with a purple sticker, must have it!

- Gin with the most awards:
 Gin of the year 2022 (best gin in the world 2022) Falstaff 91 points
 China Wine & Spirits Awards CWSA 2021 Double Gold Medal
 The Gin Guide London 2021 Gold Medal (Best of Switzerland and Top 10 in Europe)
 International Wine and Spirits Competition IWSC 2021 Silver Medal
 USA Spirits Award Gold Medal 2021 (Top 3 World)

Pot still:

- Premium column still 200 L bubble plate column

Product range:

- Gin
- Absinthe



BASANDERE DISTILLERY

Navarra, Spain

The name of this Spanish micro-distillery is Bassandere. The pot's name Maria, is also engraved on the brass door of the pot. Maria is the grandmother of the distillery owner, she was a very influential person in his life. Although the process of registering a distillery is not at all easy, the Bassandere Distillery finally opened its doors to visitors around the world in 2022.

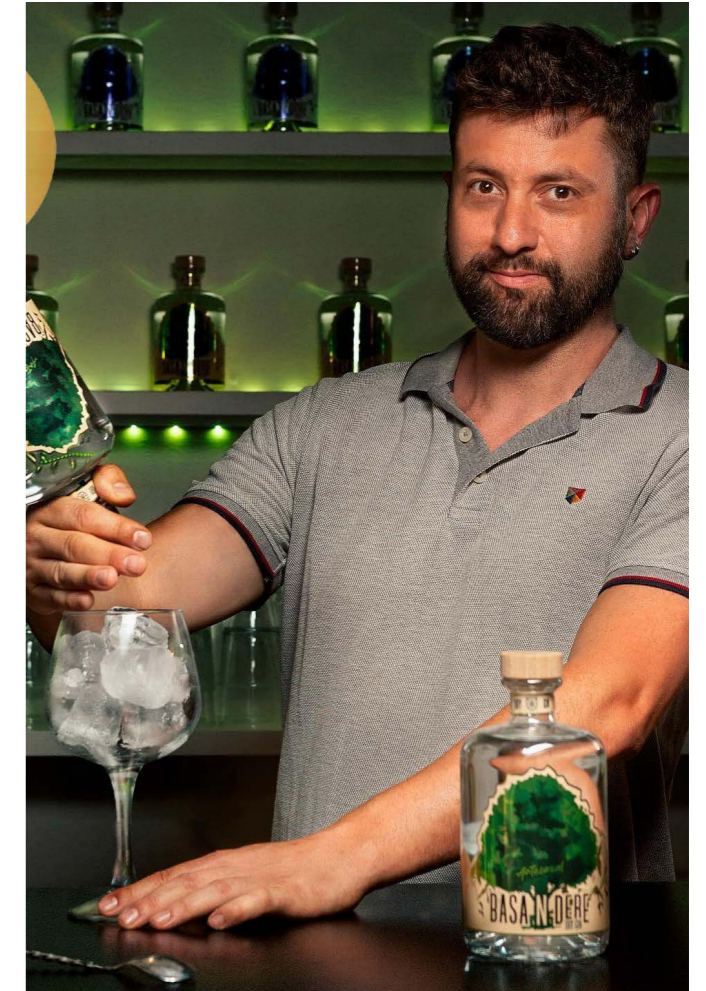

This is the first distillery in Spain that installed a DES Premium pot still. Device with a capacity of 200 L with a side column, electric heating and a basket for aromatic herbs. To begin with, they will produce different types of gin, and vodka is also planned. Only after he successfully markets his brand does he plan further development of the product range. For now, it is very clear that the flavors of these distillates do not leave anyone indifferent.

Pot still:

- Premium column still 200 L bubble plate column

Product range:

- Gin
- Vodka



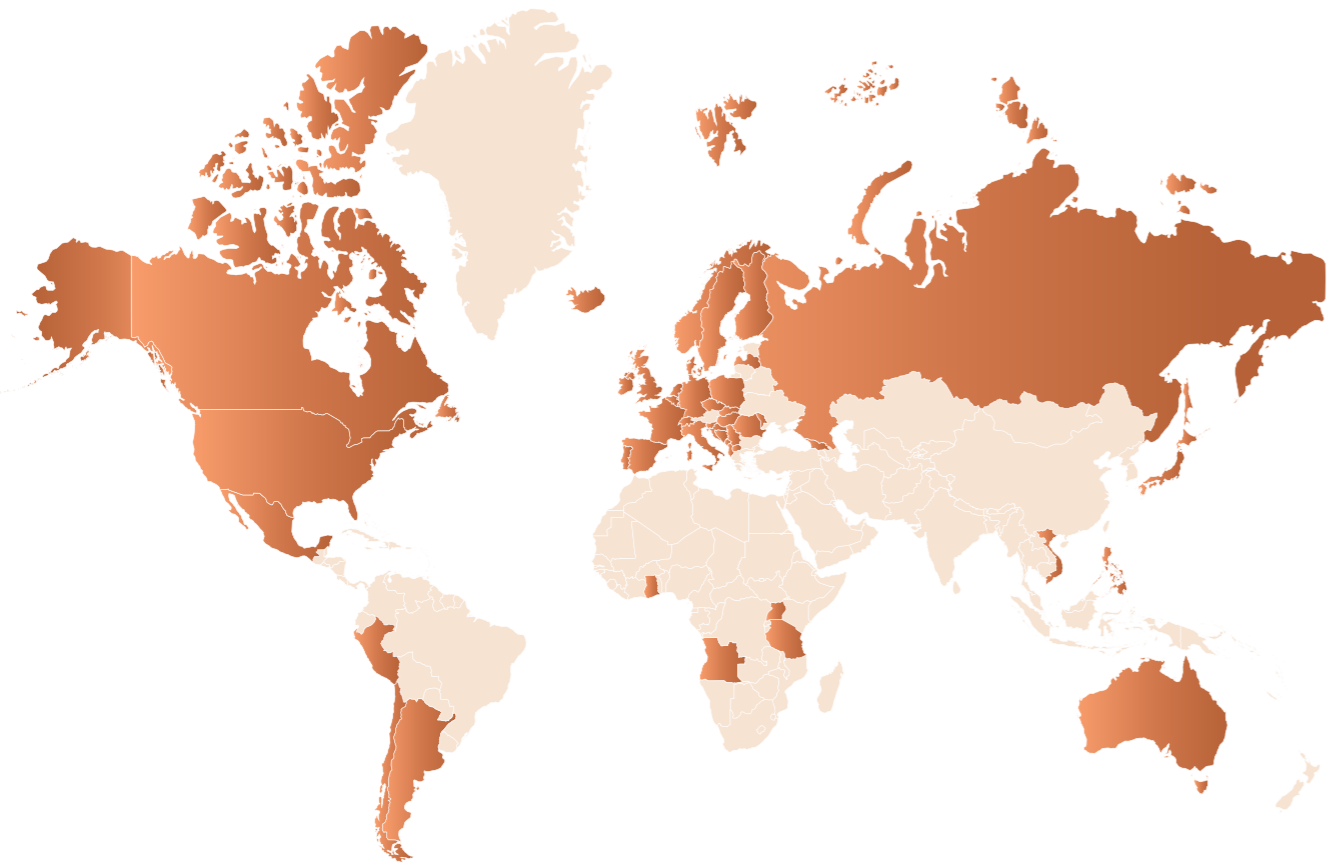

**OVER 150 CRAFT DISTILLERIES
WORLDWIDE USE
DES EQUIPMENT:**

Spain
Portugal
United Kingdom
France
Germany
Denmark
Belgium
Netherlands
Switzerland
Italy
Finland

Sweden
Norway
Poland
Latvia
Croatia
Slovenia
Serbia
Bosnia and Herzegovina
North Macedonia
Romania
Albania

Georgia
Russia
Tanzania
Ghana
Canada
Mexico
Chile
Peru
Vietnam
Japan
Australia

**Book your free video meeting presentation
with our sales representative.**
For starting up a craft distillery we offer
financing for up to 6 months.



Distilling Equipment with Soul



SCAN ME!

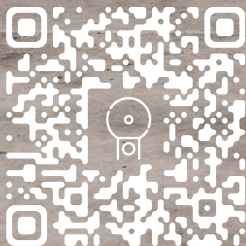

DES DOO
Gornji Verušić 58
24106 Subotica, Serbia

✉ sales@des.rs

☎ +381 64 821 5028
+381 64 821 5544

🌐 www.despotstills.eu